

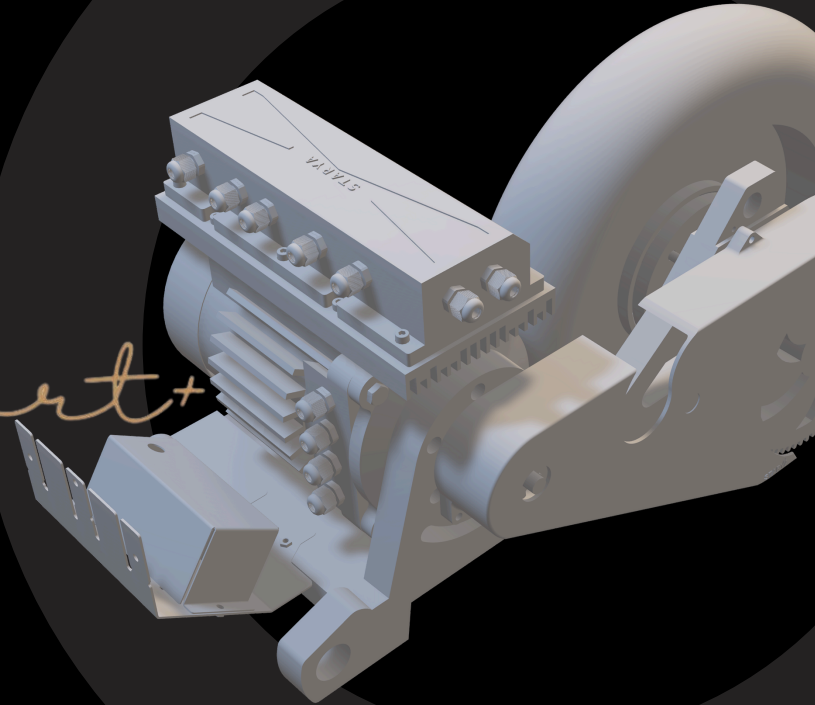

USER MANUAL

Comfort+



Rev. No: 02
Date: 13/11/2024

INDEX



• Introduction	1
• First & Foremost	4
• User Precautions	6
• Warnings	7
• About EPK 1.0	9
• Know your EPK 1.0	12
• Battery	18
• Charging	20

INDEX (Cont.)



• App	21
• Warranty	23
• Starya's Above & Beyond Warranty	25
• Limitations of Warranty	26
• Service	28
• Warranty Card	29
• Service Inquiry	34



Thank you for choosing Starya's **EPK 1.0 (Electric Propulsion Kit)**.
Educating you about our EPK & its operation is our primary objective.

Your trust & support in us is utmost valued.

You are welcome to visit our website www.starya.in & thank you again
for choosing our EPK.

INTRODUCTION



Our goal is to help people switch to sustainable solutions & lower their reliance on fossil fuels in the face of daily rising temperatures.

By providing retrofitting solutions with one of the most powerful powertrains on scooters, we pursue our mission of making performance affordable.

We have engineered our 2-kW patented PMS Motor & on your first ride, you will immediately notice the power & acceleration of the **EPK 1.0** achieving a top speed of up to 50* kmph.

Our engineers have made it possible to have your own electric scooter, with all the power & benefits of a petrol scooter (*even better*) for fraction of the price of a brand-new electric scooter.

*According to ARAI compliance

Important:



Please go through this manual thoroughly before riding your vehicle. If you have any concerns, suggestions or questions about our EPK, please reach out to us at support@starya.in.

FIRST & FOREMOST



Before using the vehicle, follow all recommendations & procedures contained in this manual. By using our EPK, you hereby agree to have thoroughly read & understood this manual's contents.

Starya Mobility Private Limited bears no liability for any risks or damages stemming from non-compliance with the provided instruction manual. Starya Mobility Pvt. Ltd. reserves the right to adjust the contents described in the manual regularly.

All rights reserved including property rights, copyrights, patents, logos etc. in this manual.

If you find any discrepancy between our products & this manual, or should you have any doubts concerning the products or the manual, please reach out to us via our website www.starya.in.



DECLARATION:

- This operation manual should be considered as a permanent part of the kit & should remain with the kit when resold, passed to a new owner or to claim warranty.
- Always carry your documents & this owners manual to claim warranty. If lost, warranty cannot be claimed.
- All the specifications, information & the photograph/images present in this manual is based on the latest information available at the time of publication.
- Any modifications or improvements of our designs will call for usage of this manual as a reference guide & all absolute amendments or changes will be made available on our website from time to time.
- Any reproduction or modification without permission is prohibited..
- Pay close attention to safety messages contained in this manual & on the vehicle.



USER PRECAUTIONS:

- The EPK has many sealed electronic parts. Do not dismantle the parts as it may damage them.
- No parts of the EPK should be submerged under water irrespective of their IP (Ingress Protection) certification.
- The storage temperature of Li-ion battery pack is +10° C to +30° C. Store it in a cool, dry space & avoid direct sunlight.
- Please charge the battery pack in an open space.
- It is advisable to cycle the battery pack from 80% to 20% before recharging for better cycle life. Keep the SOC of the pack at 30% for better shelf life. If the battery pack is being unused for more than 3 months, please reach out to authorized Starya conversion points for safe keeping.



WARNING SIGNS



This symbol indicates “May Cause Fire”.



This symbol indicates “High Voltage”. Extreme care should be taken to protect against shock. Do not operate with wet hands.



WARNING:

- Avoid exposure to live contacts (Battery pack & Charger) when hands, feet or body is wet or even when standing on a wet floor. Do not short positive & negative terminals.
- Not wearing a helmet increases the chance of a serious injury or death in a crash. Make sure that you & your pillion rider always wear an approved helmet & protective apparel.
- Overloading or improper loading can cause a crash & you can be seriously hurt or killed. Follow all load limits & other loading guidelines mentioned in this manual.
- Tampering with EPK components or electrical wiring or adding external modifications are prohibited. Any non-compliance can cause electrical hazard & voids warranty.

About EPK 1.0



Powertrain

- Motor Type PMSM
- Peak Power 2 kW
- Nominal Power 1.6 kW
- Torque 24 Nm
- Motor IP Rating IP65
- Drive Type Belt Driven
- Controller Type FOC
- Operating Voltage 40-67 V
- Controller IP Rating IP65

Battery & Charger

- Battery Type Li-ion NMC
- Capacity 2 kW
- Charging Time (10-90%) 3.4 Hrs
- Charger Type CC/CV
- Charging Output 54.6 V/10 A

WARNING:

- Always use recommended battery & charger. Any use of unauthorised battery & charger will void all the warranties.
- Maximum weight of the vehicle should not exceed 200 Kgs.

About EPK 1.0



Vehicle Specs

- Top Speed 50 Km/h*
- Gradeability 9°
- Unladen Weight 114 Kgs. (+/-5%)
- GVW 264 Kgs.
- Ground Clearance 150 mm

Brakes

- Front Drum/Disk
- Rear Drum

*Top speed of the vehicle is tested & claimed by ARAI

Tyre

- Front Tyre Size 90/100-10 53J Tubeless
90/90-12 54J Tubeless
- Rear Tyre Size 90/100-10 53J Tubeless

Range (100% - 0%)

- Eco 75-85 Kms**
- City 50-60 Kms**

**Claimed range is subjected to single rider with an average weight of 75 Kgs.
Range may vary depending on terrain & ride pattern.

About EPK 1.0 - Layout

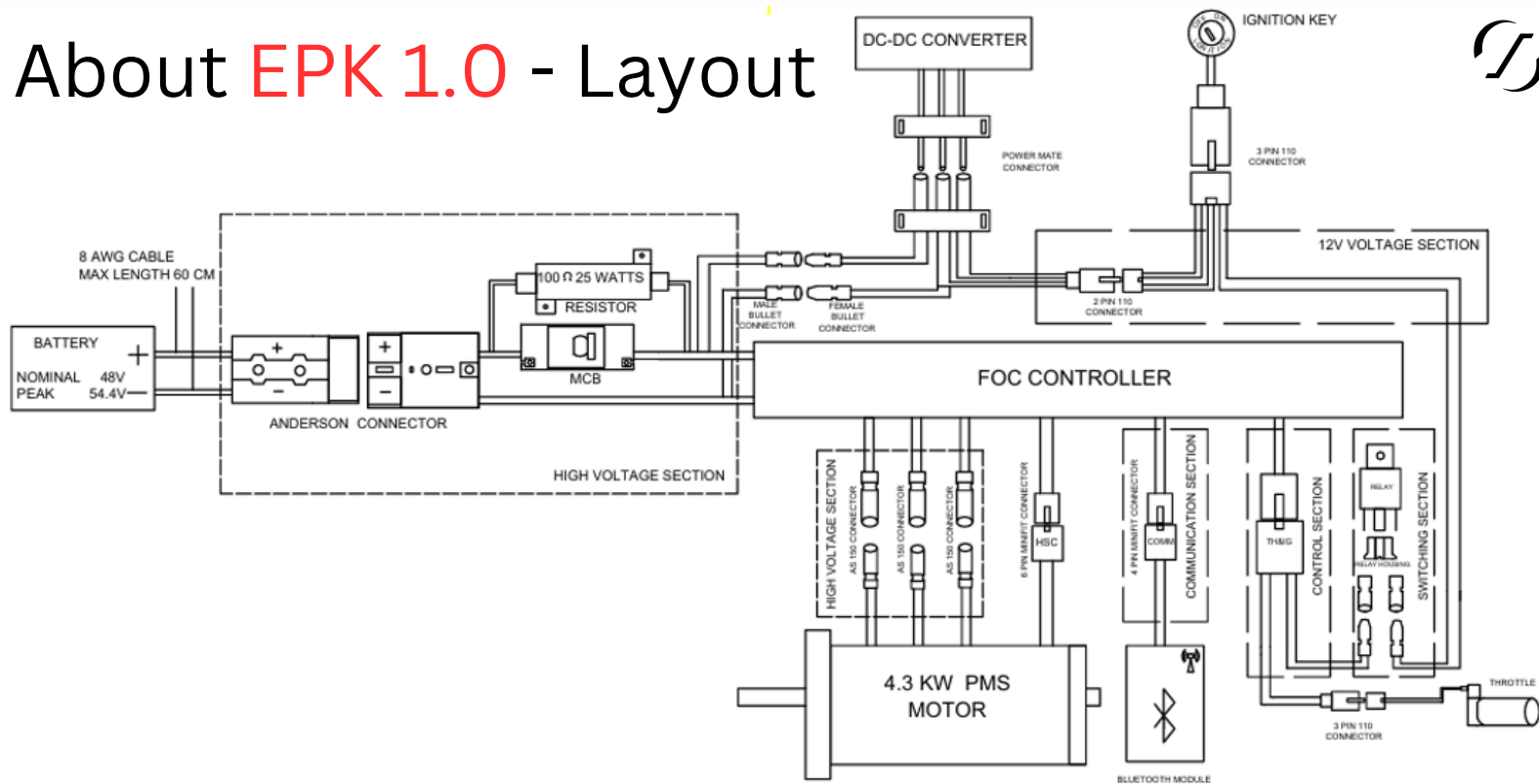

Know your EPK 1.0

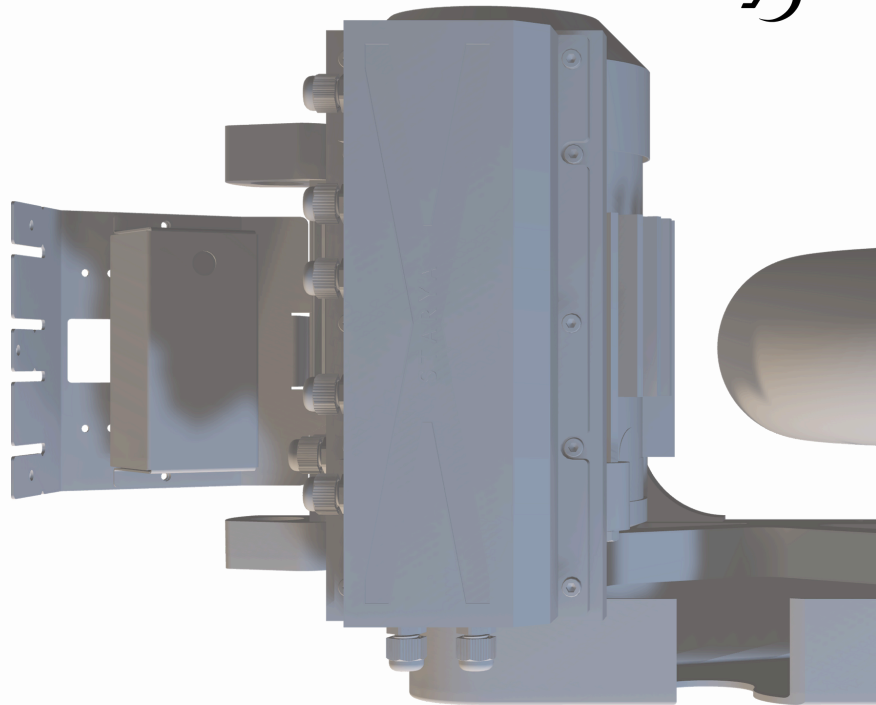

How to start your Vehicle

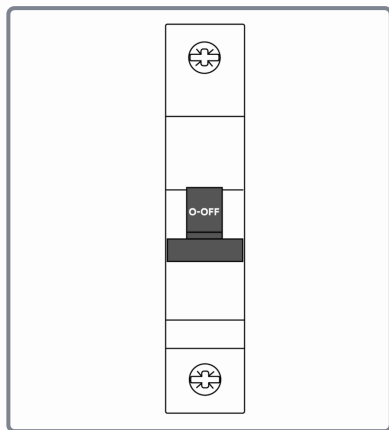

1

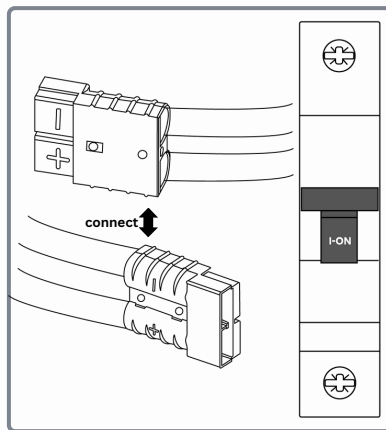

2

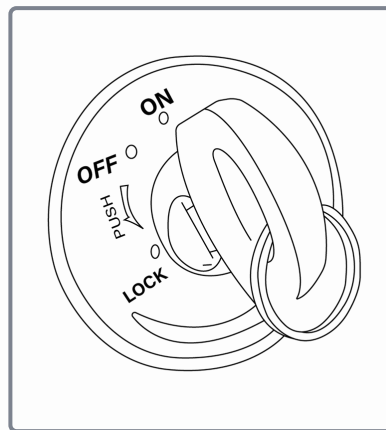

3

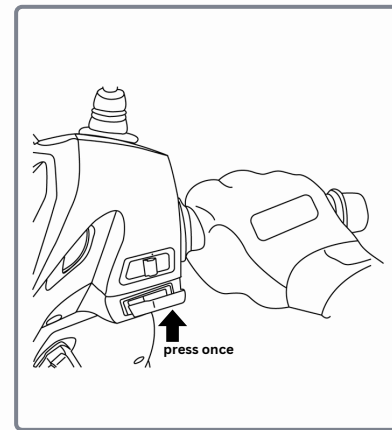

4

How to start your Vehicle



Prerequisites :

1. Ensure the MCB is turned off.
2. Place the battery in the battery compartment & connect the battery's connector to the socket provided in the vehicle & turn on the MCB.
3. Turn ON the ignition key.
 - a. A red light turns ON in the fault indicator indicating a system boot up.
 - b. If there are no faults in the system, the red light turns green & starts blinking indicating vehicle's idle state.
 - c. At this point, the fuel gauge starts displaying the battery SOC status.
4. Press the Power start button on the handle once. The green light turns solid & vehicle can now be accelerated.

Reverse Mode



- If Vehicle is turned off, please refer to the steps listed under **Prerequisites**.
- Press & hold the power start button on the handle bar & turn on the ignition key & release the power start button after 3-5 seconds.
- The fault indicator blinks  in this format indicating the vehicle in reverse mode.
- To turn off the reverse mode, turn off the ignition key & turn it on again & follow the steps in “How to start your vehicle”.

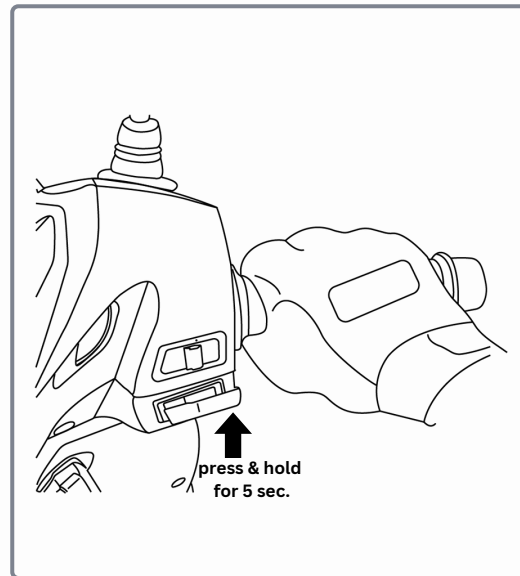

About Miniature Circuit Breaker (MCB)





- While removing & inserting the battery connector from the vehicle, make sure the MCB is turned off. If not, it produces sparks & might damage the controller.
- Make sure there is no moisture in the connector terminals & MCB. Always blow dry.

Vehicle Wash

- Motor, Controller & Battery has an Ingress Protection rating of IP65. “6” represents the product is highly resistant to dust, & “5” represents it can withstand low pressure water jets. IP65 rated products are suitable for outdoor use in most situations, but they aren’t fully waterproof & shouldn’t be submerged underwater. Do not point the water jet directly onto the motor & controller, instead use a damp wet cloth to clean. Do not wash battery compartment.
- Before washing the vehicle, make sure to remove the battery & kept far from water while using low pressure water jets. Before inserting the battery, ensure to wipe dry/blow air the connectors & other products to prevent damage.



Fault Indications

	ON	Vehicle ON/Ready to move
	ON	Kit fault
	BLINK	Motor over temperature fault

- **Low Voltage:**

The fault light indicates in this manner



Battery



Specifications

- Nominal voltage 48 V
- Full charge voltage 54.6 V
- Discharge voltage 40 V
- Battery capacity 44 Ah
- Connector type Anderson SB50/
Anderson SBS75X

- Chemistry NMC
- IP Rating IP65
- Battery type Removable
- Weight 14 Kgs.
- Enclosure Mild Steel



Do's & Don'ts

- Use battery charger provided by the company. Do not use any other charger.
 - It is strongly recommended that the battery should not be overcharged.
 - Keep battery away from water. Might damage the battery if exposed to water & also cause internal short circuits. Do not wash the battery. Gently wipe it with a clean microfiber cloth.
 - User should not park their vehicles in waterlogged/flooded areas.
 - Do not damage the battery's output cables as it will lead to external short circuits. If found any damage on the cables, immediately contact your nearest authorised Starya dealer & get it repaired or replaced.
- Do not damage the battery connector as it will lead to loose contacts & might produce sparks.
 - Do not damage the glands on the pack. It will lead to the damage of output cables & jeopardise the ingress protection.
 - Do not pull or lift the battery pack using output cables. A handle is provided for the same.
 - Battery must be handled with care to avoid any physical damages. Do not apply pressure, drop the pack, mishandle etc. It may lead to malfunction or damage the battery.
 - Keep the battery away from reach of children.
 - Charge & discharge the battery at-least once a month if not being used for a longer duration of time. While storing, ensure the battery SOC is at-least 20%.

Charging



Procedure to charge the battery:

1. Connect the charger's connector to the battery connector. Make sure the terminals are matched.
2. Connect the charger's 3 pin plug to your AC mains. Turn on the mains switch.

- A green light is turned on indicating power supply to the charger.
- If the red light is blinking under 50%, it indicates the battery SOC is under 50%.
- If red light is solid under 50% & red light is blinking under 100%, it indicates that the SOC is in between 50% - 100%.
- If both the red lights are turned on & not blinking, it indicates that the battery is fully charged.

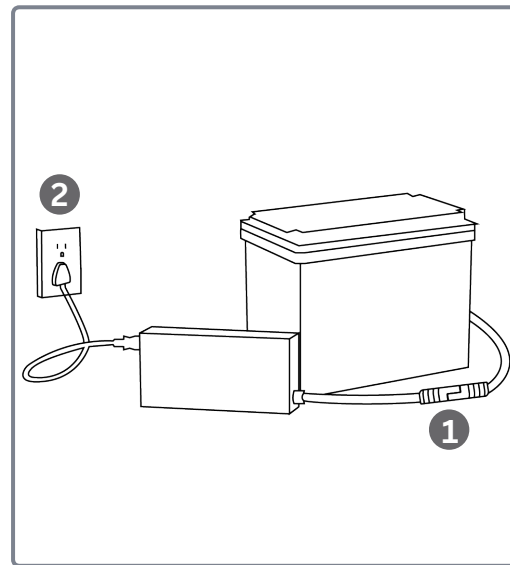

ATTENTION:

If the charger is connected to the power supply first & then connected to the battery, the charger indicates that the battery is fully charged even though the pack is not charging/charged. Please follow the above-mentioned steps accordingly to charge your battery. Also, check the display on the battery pack to know the current SOC.



App

Sign Up

- Once the app has been downloaded, open & allow all the permissions that the app is requesting & sign up.
- Fill in your details. A verification code will be sent to your mobile number to verify the user.
- Read the instructions & continue. A Bluetooth pair key notification pops up. Tap on OK.
- The pair key will be copied automatically. Now go to your device Bluetooth settings & find your vehicle's Bluetooth ID & pair.
- Now paste the copied Bluetooth pair key & connect to your vehicle.



Scan the QR to
download the app.

Compatible with Android
version 10 & above & IOS
version 12 & above.



App

Sign In

- Open the app & allow all the permissions (Location services, Bluetooth)
- Tap on sign in.
- Enter your registered mobile number. A verification code will be sent to your mobile number to verify the user.
- Read the instructions & continue.

Changing Modes

- Once connected to the vehicle, tap on the 3 vertical lines located at the top left.
- Go to settings & choose the mode you want to ride in.
- Regen is turned on by default in eco and city modes. Auto boost is enabled in sports mode.



Warranty

- **On Battery & Charger**

- The warranty on the battery shall exist for a period of **30 months or 30,000 kms** (whichever comes earlier) as subjected to SOH of the battery from the date of delivery of the retrofitted scooter. SOH degradation drop of **10%** on year-on-year basis is expected on all battery packs.
- The charger has a warranty for **6 months** from the date of delivery.

- **On Motor**

- The warranty on the motor shall exist for a period of **24 months or 24,000 kms**(whichever comes earlier) from the date of delivery.
- Below are the components the warranty applies for:
 1. Windings
 2. Motor Body & Drive End
 3. Rotor
 4. Stator



- **On Controller**

- The warranty on the controller shall exist for a period of **12 months or 12,000 kms** (whichever comes earlier) from the date of delivery.

- **On Swingarm Chassis & Transmission Belt**

- The warranty on the swingarm chassis shall exist for a period of **12 months or 12,000 kms** (Whichever comes earlier) from the date of delivery.
- The warranty on the transmission belt shall exist for a period of **5 months or 5,000 kms** (Whichever comes earlier) from the date of delivery.

- **5 Months or 5,000 kms (Whichever is earlier)**

- The components under warranty for the above-mentioned period are,

1. Motor Pulley

2. Axle Pulley

3. Bearings

4. Throttle

5. Miniature Circuit Breaker (MCB)

6. DC-DC Converter

7. Wiring Harness

Starya's Above & Beyond Warranty



STARYA MOBILITY PRIVATE LIMITED (“Company”) warrants that each new EPK’s manufactured by the company shall be free from any defects in both materials & workmanship, under normal use & maintenance, subject to the following terms & conditions.

- The company will repair or replace, at no cost, any EPK parts that are found to be faulty in manufacturing or workmanship within the warranty period above. The company will decide whether to repair or replace the faulty part & its decision is final. The company will own any parts that are replaced.
- The company is responsible for all labour costs for the above replacement or repair within the warranty period.

Limitations of Warranty



This warranty shall not apply under the following conditions:

- The warranty of EPK components that are repaired or replaced lasts only until the end of the original warranty period.
- Damage to EPK parts & related components caused by an accident, misuse or negligence.
- Any scooter parts that wear out or get old naturally are not covered by the warranty.
- Parts & consumables like Brake liners, Brake pads, Brake disks, Brake drums, tyre bushes, rubber parts, grommets, seals, oil suspension system, grease & fasteners will not be covered under warranty.
- Improper maintenance, misuse, abuse, accidents, thefts, flooding, fire or racing, competing with the scooter, using for commercial purposes, or using for any illegal activities can damage the scooter & void the warranty.
- Any incidental, remote, indirect or consequential damages, resulting in loss of scooter use or commercial loss from using the scooter, are not the company's responsibility.



- The company is not liable for any delay in servicing due to reasons beyond the control of the company or any authorised conversion points.
- The company may modify or improve the EPK in the future at any time without prior notice and without any obligation to install the same.
- This warranty is the sole warranty for the Starya's retrofitted scooters from the company & no employee is allowed to alter or enhance this warranty. The company does not accept any oral warranty from any dealer, agent or an employee.
- The company reserves the right to the final decision in all warranty matters.

WARNING:

To maintain the validity of the warranty, the vehicle must be serviced at Starya Authorized Conversion Points only at all times.

Service

Customers should follow the service history as per the company standards.

*The components will be replaced without any additional charges if it is within the warranty period.

*The free service covers only labour costs and does not include spare parts.

Preventive Maintenance Chart									
A - Adjust	I - Inspect			R - Replace			C - Clean		
Description	Free Service		Paid Service						
	1000 kms / 1 month	4500 / 4 months	8000 / 8 months	12000 / 12 months	16000 / 16 months	20000 / 20 months	24000 / 24 months	28000 / 28 months	32000 / 32 months
SOH of SIU*	I	I	I	I	I	I	I	I	I
Loose Connections	I, A or R	I, A or R	I, A or R	I, A or R	I, A or R	I, A or R	I, A or R	I, A or R	I, A or R
SOH of Battery Pack*	I	I	I	I	I	I	I	I	I
Fasteners	A	A	A	A	A	A	A	A	A
Wear Level of Motor Pulley*	-	I & R	-	I & R	-	I & R	-	I & R	-
Erratic Noises	I & A	I & A	I & A	I & A	I & A	I & A	I & A	I & A	I & A
Visual Damages	I	I	I	I	I	I	I	I	I
Wheel Bearing Freeness	I & R	I & R	I & R	I & R	I & R	I & R	I & R	I & R	I & R
Motor Bearing Freeness	I & R	I & R	I & R	I & R	I & R	I & R	I & R	I & R	I & R
Latest Firmware	I	I	I	I	I	I	I	I	I
Bear Health*	I & R	I & R	I & R	I & R	I & R	I & R	I & R	I & R	I & R
Brake Shoe (Front)	I & R	I & R	I & R	I & R	I & R	I & R	I & R	I & R	I & R
DC - DC Converter*	I & R	I & R	I & R	I & R	I & R	I & R	I & R	I & R	I & R
Anderson Connector	I & R	I & R	I & R	I & R	I & R	I & R	I & R	I & R	I & R
Anderson Lugs	I & R	I & R	I & R	I & R	I & R	I & R	I & R	I & R	I & R
Suspension Spring Health	-	I & R	-	I & R	-	I & R	-	I & R	-
Wheel Alignment	-	I & R	-	I & R	-	I & R	-	I & R	-
Cone Set Bearing	I & R	I & R	I & R	I & R	I & R	I & R	I & R	I & R	I & R
Green Bush Set	I & R	I & R	I & R	I & R	I & R	I & R	I & R	I & R	I & R
Fork Bend	I & A	I & A	I & A	I & A	I & A	I & A	I & A	I & A	I & A
Speedometer Cable & Worm Set	I, A or R	I, A or R	I, A or R	I, A or R	I, A or R	I, A or R	I, A or R	I, A or R	I, A or R
Brake Shoe (Rear)	I & R	I & R	I & R	I & R	I & R	I & R	I & R	I & R	I & R
Washing	C	C	C	C	C	C	C	C	C
Polishing	C	C	C	C	C	C	C	C	C

Warranty Card

(Customer's Copy)



- **Vehicle Reg. Number**

- **Vehicle Model**

- **Date of Delivery**

- **EPK Number**

- **Motor Number**

- **Controller Number**

- **Battery Number**

- **Charger Number**

Warranty Card

(Customer's Copy)



• **Owner's Name**

• **Mobile Number**

• **City/State**

• **Pin**

• **Invoice Number**

• **VIN/Frame Number**

I hereby confirm the warranty terms & conditions have been explained to me. I agree to use this vehicle as per terms & conditions.

Seal & Sign of the Dealer

Customer's Signature

Warranty Card (Dealer's Copy)



- **Vehicle Reg. Number** _____
- **Vehicle Model** _____
- **Date of Delivery** _____
- **Chassis Number** _____
- **Motor Number** _____
- **Controller Number** _____
- **Battery Number** _____
- **Owner's Name** _____
- **Mobile Number** _____
- **City/State** _____ / _____
- **Pin** _____
- **Invoice Number** _____
- **VIN/Frame Number** _____
- **Charger Number** _____

Seal & Sign of the Dealer

Customer's Signature

I hereby confirm the warranty terms & conditions have been explained to me. I agree to use this vehicle as per terms & conditions.

Warranty Details



Date of Replacement	Product	Serial Number	Warranty Until	Signature
_____	_____	_____	_____	_____
_____	_____	_____	_____	_____
_____	_____	_____	_____	_____
_____	_____	_____	_____	_____
_____	_____	_____	_____	_____

Warranty Details



Date of Replacement	Product	Serial Number	Warranty Until	Signature
_____	_____	_____	_____	_____
_____	_____	_____	_____	_____
_____	_____	_____	_____	_____
_____	_____	_____	_____	_____
_____	_____	_____	_____	_____



For any service-related inquiries, please call +91 63609 00247.

If calling from your registered mobile number:

Press 2 to be redirected to the Starya Service Centre.

If calling from a non-registered mobile number:

After pressing 2, enter the last 4 digits of your vehicle's registration number to be redirected to the Starya Service Centre.



STARYA

Reborn Electric

www.starya.in